



LC Series-Lead Carbon

LC2-500



Specifications

Rated Voltage	2V	
Nominal Capacity	500Ah	(C ₁₀ , 1.80V/cell)
Dimension	Length	191mm (7.52 in.)
	Width	181mm (7.13 in.)
	Container Height	350mm (13.78 in.)
	Total Height	365mm (14.37 in.)
Approx Weight	30.6 Kg (67.5 lbs)	
Terminal	M8	
Container Material	ABS Flame Retardant Material to UL94V-0	
Rated Capacity (25°C)	654.0 Ah	C120(5.45A, 1.85V/cell)
	500.0 Ah	C10(50.0A, 1.80V/cell)
	375.0 Ah	C3(125.0A, 1.80V/cell)
	275.1 Ah	C1(275.1A, 1.75V/cell)
Max. Discharge Current	3100A	
Internal Resistance (25°C)	Approx.0.45mΩ	
Operating Temp.Range	Discharge	-20°C~55°C (-4°F~131°F)
	Charge	-20°C~40°C (-4°F~104°F)
	Storage	-20°C~50°C (-4°F~122°F)
Nominal Operating Temp. Range	25±3°C (77±5°F)	
Max.Discharging Current(25°C)	200.0A	
Max.Charging Current(25°C)	100.0A	
Charge voltage	Cycle(Equalization)	2.35~2.40V
	Temp. Coefficient	-4mV/cell/°C
Effect of temp. to Capacity	40°C (104°F)	106%
	25°C (77°F)	100%
	0°C (32°F)	86%
Self Discharge	≤4% per month at 25°C	



Layout

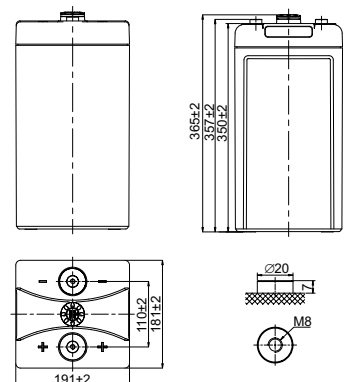

Constant Current Discharge (Amperes) at 25 °C (77°F)

F.V/Time	1h	2h	3h	4h	5h	6h	8h	10h	24h	36h	48h	60h	72h	84h	96h	108h	120h	240h
1.90V/cell	208.5	137.0	103.7	88.0	73.7	63.9	51.9	44.7	22.1	14.9	11.5	/	/	/	/	/	/	2.80
1.85V/cell	231.4	146.5	114.7	94.6	79.3	68.9	56.0	48.3	24.0	16.3	12.5	10.0	8.50	7.50	6.70	6.00	5.45	/
1.80V/cell	255.2	156.1	125.0	98.3	82.4	71.5	58.1	50.0	24.5	16.6	12.7	/	/	/	/	/	/	/
1.75V/cell	275.1	162.7	127.7	100.2	84.0	72.9	59.2	51.0	25.0	16.9	13.0	/	/	/	/	/	/	/

Constant Power Discharge (Watts/cell) at 25 °C (77°F)

F.V/Time	1h	2h	3h	4h	5h	6h	8h	10h	24h	36h	48h	60h	72h	84h	96h	108h	120h	240h
1.90V/cell	408.1	271.2	208.3	178.2	149.4	129.7	105.5	90.9	43.1	29.2	22.4	/	/	/	/	/	/	5.60
1.85V/cell	454.8	287.4	227.1	188.8	158.8	138.1	112.8	97.6	45.1	30.5	23.4	20.0	17.0	15.0	13.4	12.0	10.9	/
1.80V/cell	494.5	301.7	246.6	195.0	164.0	142.7	116.5	100.8	46.6	31.5	24.2	/	/	/	/	/	/	/
1.75V/cell	519.3	314.0	250.3	198.4	166.6	144.8	118.0	101.9	47.5	32.2	24.7	/	/	/	/	/	/	/



LC Series-Lead Carbon

LC2-500



Applications

- Smart grid system
- Hybrid power supply system
- Cyclic used in unstable grid
- Home energy storage system
- Renewable energy storage systems
- Street lamp centralized power supply system
- Distributed and Micro-grid energy storage system
- Renewable energy communication base station power supply system

General Features

- Design life ≥ 12 years
- Adopt super carbon technology + deep cycle technology
- Excellent charging acceptance and super fast charge/large discharge performance
- Modular design and installation for less space, easy installation & maintenance
- Innovative robust design to ensure superb safety and reliability

Standards

- Compliance with IEC 61427, BS EN 61427 standards
- UL, CE Certified

Discharge Characteristics

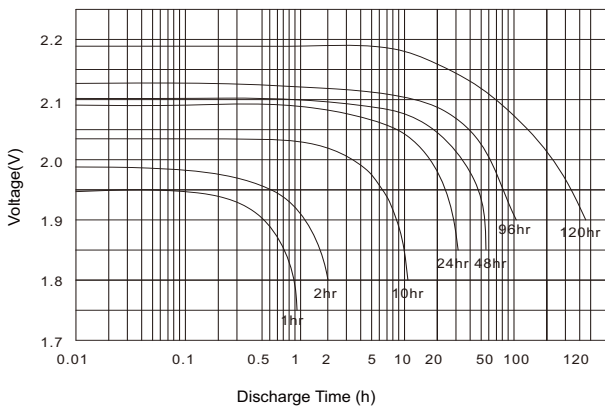

Temperature effects in relation to battery capacity

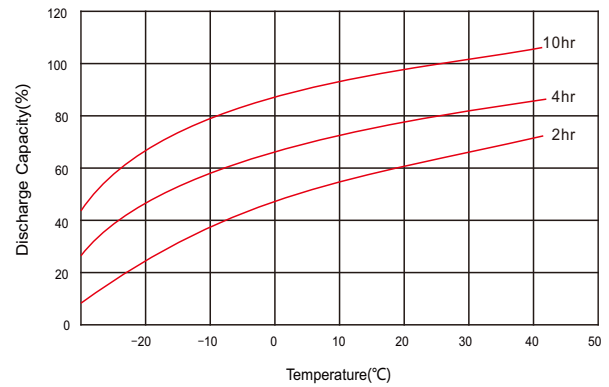

Cycle Life in Relation to DOD

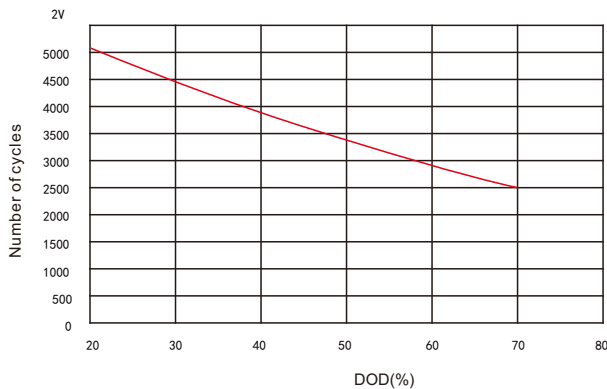

Self Discharge Characteristics

