



URC Series-Lead Carbon

URC2-600

UPLUS
NEW TECHNOLOGY BATTERY

Specifications

Rated Voltage	2V	
Nominal Capacity	643Ah	(C ₁₀ , 1.80V/cell)
Dimension	Length	303mm (11.93 in.)
	Width	181mm (7.13 in.)
	Container Height	350mm (13.78 in.)
	Total Height	365mm (14.37 in.)
Approx Weight	47.5Kg (104.7lbs)	
Terminal	M8	
Container Material	ABS Flame Retardant Material to UL94V-0	
Rated Capacity (25°C)	643 Ah	(10hr, 64.3A, 1.80V/cell)
	563.5 Ah	(5hr, 112.7A, 1.75V/cell)
	483.6 Ah	(3hr, 161.2A, 1.75V/cell)
Short Circuit Current	6000A	
Internal Resistance(25°C)	Approx. 0.4mΩ	
Operating Temp. Range	Discharge	-20°C~55°C (-4°F~131°F)
	Charge	0°C~40°C (32°F~104°F)
	Storage	-20°C~50°C (-4°F~122°F)
Nominal Operating Temp. Range	25±3°C (77±5°F)	
Max. Discharging Current(25°C)	300.0A	
Max. Charging Current(25°C)	180.0A	
Charge voltage(25°C)	Cycle(Equalization)	2.30~2.40V
	Temp. Coefficient	-4mV/cell/°C
Effect of temp. to Capacity	40°C (104°F)	106%
	25°C (77°F)	100%
	0°C (32°F)	86%
Self Discharge	≤3.5% per month at 25°C	



Layout

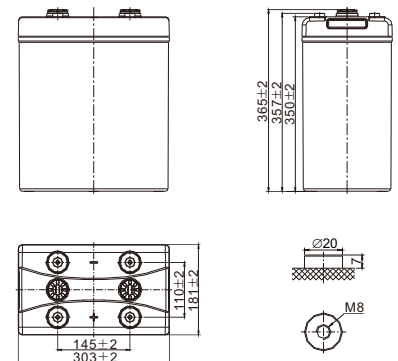

Constant Current Discharge (Amperes) at 25 °C (77 °F)

F.V/Time	15min	30min	1h	3h	5h	8h	10h	20h	48h
1. 90V/cell	490.8	366.3	259.2	138.1	102.3	72.3	60.5	32.8	14.0
1. 85V/cell	576.7	426.5	292.8	147.9	106.4	75.2	62.5	33.6	14.3
1. 80V/cell	655.6	478.5	324.0	156.4	110.2	77.3	64.3	34.8	14.8
1. 75V/cell	800.3	510.4	346.8	161.2	112.7	78.9	65.9	35.4	15.1

Constant Power Discharge (Watts/cell) at 25 °C (77 °F)

F.V/Time	15min	30min	1h	3h	5h	8h	10h	20h	48h
1. 90V/cell	958.8	736.4	535.5	279.5	200.9	134.6	112.2	67.6	28.7
1. 85V/cell	1103.6	872.1	620.2	301.9	207.1	144.8	121.4	69.8	29.8
1. 80V/cell	1211.8	980.2	682.4	318.2	214.2	148.9	126.5	72.6	30.9
1. 75V/cell	1271.9	1016.9	698.7	329.5	220.3	154.0	128.5	78.1	31.5



URC Series-Lead Carbon

URC2-600



Applications

- Mobile container storage system
- Peak load shifting energy storage system
- Load tracking energy storage system
- Oil and electricity hybrid energy storage system
- Grid frequency adjustment energy storage system
- New energy communication base station, IDC, UPS etc.
- New energy generation (solar, wind, PV/wind hybrid) access to energy storage systems

General Features

- Design life ≥ 15 years
- Adopt super carbon technology + deep cycle technology
- Excellent charging acceptance and super fast charge/large discharge performance
- Modular design and installation for less space, easy installation & maintenance
- Innovative robust design to ensure superb safety and reliability
- Horizontal installation, solve the problem of electrolyte stratification

Standards

- Compliance with IEC 61427, BS EN 61427 standards
- Manufactured in UPLUS@TS16949 OHSAS 18001, ISO 9001 and ISO 14001 certified production facilities

Discharge Characteristics

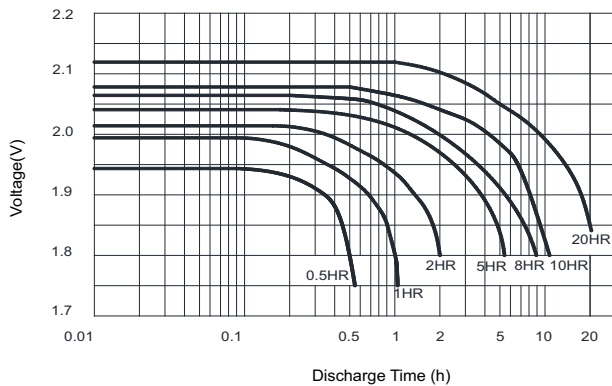

Temperature effects in relation to battery capacity

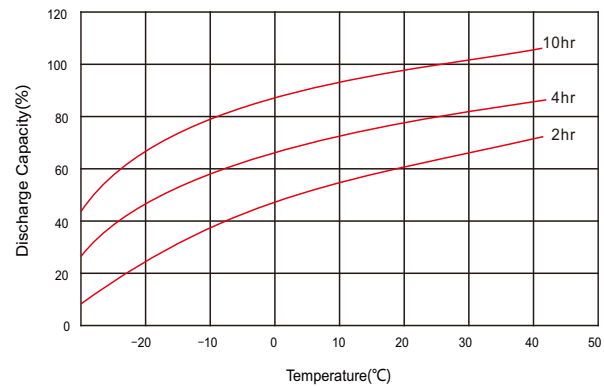

Cycle Life in Relation to DOD

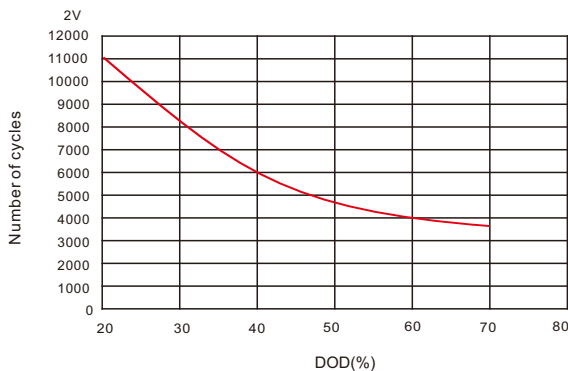

Self Discharge Characteristics

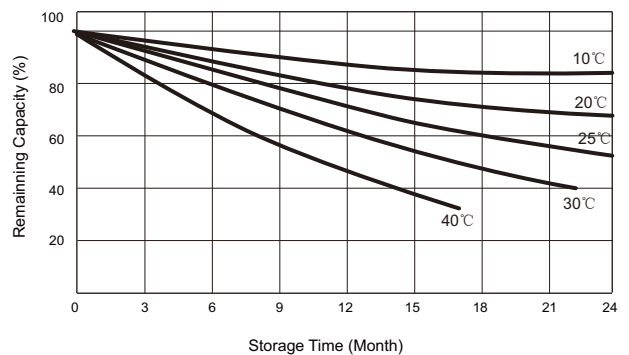

ANHUI UPLUS ENERGY TECHNOLOGY CO., LTD.

