



# URC Series-Lead Carbon

## URC2-800



### Specifications

Rated Voltage	2V	
Nominal Capacity	857Ah	(C <sub>10</sub> , 1.80V/cell)
Dimension	Length	370mm (14.57 in.)
	Width	181mm (7.13 in.)
	Container Height	350mm (13.78 in.)
	Total Height	365mm (14.37 in.)
Approx Weight	60.5Kg (133.4lbs)	
Terminal	M8	
Container Material	ABS Flame Retardant Material to UL94V-0	
Rated Capacity (25°C)	857 Ah	(10hr, 85.7A, 1.80V/cell)
	740 Ah	(5hr, 148.0A, 1.75V/cell)
	638.1 Ah	(3hr, 212.7A, 1.75V/cell)
Short Circuit Current	7040A	
Internal Resistance(25°C)	Approx. 0.4mΩ	
Operating Temp. Range	Discharge	-20°C~55°C (-4°F~131°F)
	Charge	0°C~40°C (32°F~104°F)
	Storage	-20°C~50°C (-4°F~122°F)
Nominal Operating Temp. Range	25±3°C (77±5°F)	
Max. Discharging Current(25°C)	400.0A	
Max. Charging Current(25°C)	240.0A	
Charge voltage(25°C)	Cycle(Equalization)	2.30~2.40V
	Temp. Coefficient	-4mV/cell/°C
Effect of temp. to Capacity	40°C (104°F)	106%
	25°C (77°F)	100%
	0°C (32°F)	86%
Self Discharge	≤3.5% per month at 25°C	



### Layout

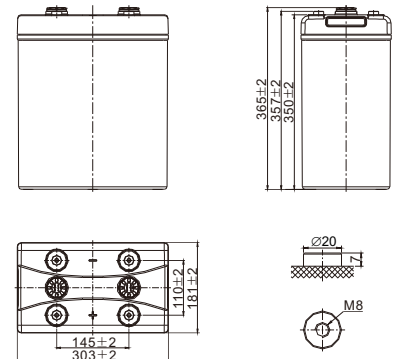

### Constant Current Discharge (Amperes) at 25 °C (77 °F)

F.V/Time	15min	30min	1h	3h	5h	8h	10h	20h	48h
1. 90V/cell	663.5	493.3	343.7	182.4	134.4	88.9	75.1	43.6	18.6
1. 85V/cell	779.7	574.5	388.2	195.1	139.7	97.9	82.4	44.5	19.1
1. 80V/cell	886.3	644.4	429.6	206.3	144.6	102.0	85.7	46.1	19.7
1. 75V/cell	1082.0	687.4	459.8	212.7	148.0	104.4	87.3	46.9	20.1

### Constant Power Discharge (Watts/cell) at 25 °C (77 °F)

F.V/Time	15min	30min	1h	3h	5h	8h	10h	20h	48h
1. 90V/cell	1296.4	991.4	709.9	369.2	263.2	194.8	166.3	89.6	38.3
1. 85V/cell	1492.3	1174.0	823.1	397.8	271.3	208.1	176.5	92.6	39.7
1. 80V/cell	1639.1	1320.9	905.8	420.2	281.5	220.3	185.6	96.4	41.3
1. 75V/cell	1719.7	1369.9	926.2	434.5	289.7	225.4	189.7	98.1	42.0



# URC Series-Lead Carbon

## URC2-800



### Applications

- Mobile container storage system
- Peak load shifting energy storage system
- Load tracking energy storage system
- Oil and electricity hybrid energy storage system
- Grid frequency adjustment energy storage system
- New energy communication base station, IDC, UPS etc.
- New energy generation (solar, wind, PV/wind hybrid) access to energy storage systems

### General Features

- Design life  $\geq 15$  years
- Adopt super carbon technology + deep cycle technology
- Excellent charging acceptance and super fast charge/large discharge performance
- Modular design and installation for less space, easy installation & maintenance
- Innovative robust design to ensure superb safety and reliability
- Horizontal installation, solve the problem of electrolyte stratification

### Standards

- Compliance with IEC 61427, BS EN 61427 standards
- Manufactured in UPLUS@TS16949 OHSAS 18001, ISO 9001 and ISO 14001 certified production facilities

### Discharge Characteristics

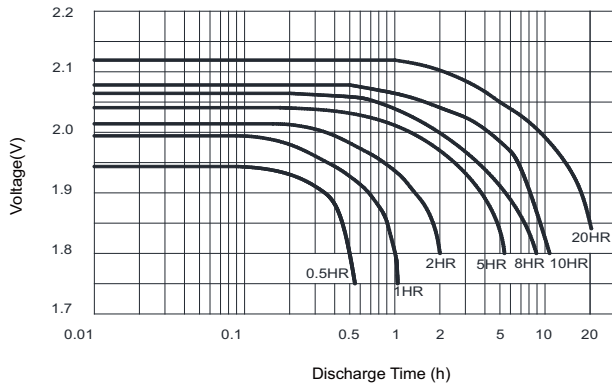

### Temperature effects in relation to battery capacity

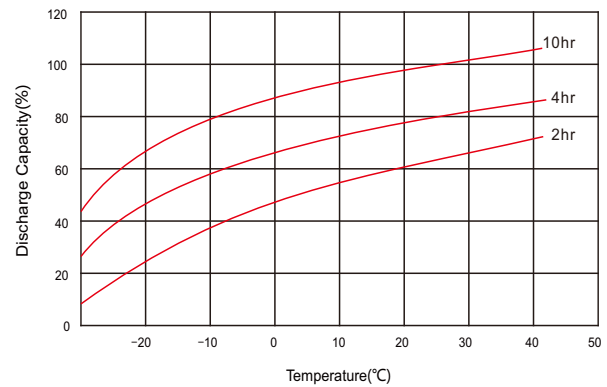

### Cycle Life in Relation to DOD

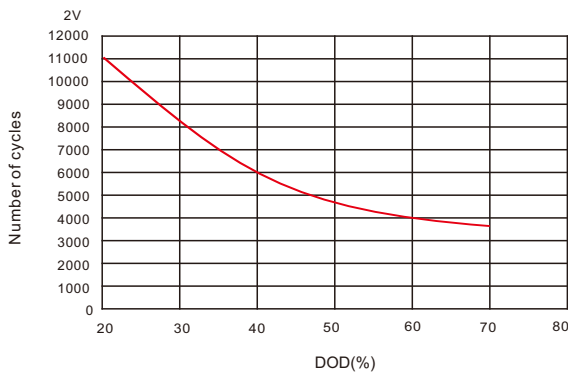

### Self Discharge Characteristics

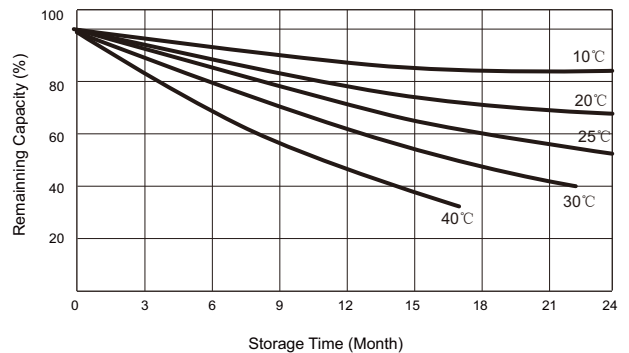

ANHUI UPLUS ENERGY TECHNOLOGY CO., LTD.

