



# US Series-General Purpose US12-14(12V14Ah)



## Specifications

Rated Voltage	12V	
Nominal Capacity	14.0Ah	(C <sub>20</sub> , 1.80V/cell)
Dimension	Length	151±2mm (5.95 inches)
	Width	98±1mm (3.86 inches)
	Container Height	95±1mm (3.74 inches)
	Total Height	101±2mm (3.98 inches)
Approx Weight	3.90 Kg (8.60 lbs)	
Terminal	T1/T2	
Container Material	ABS	
Rated Capacity (25°C)	14.0 Ah	(20hr, 0.700A, 1.80V/cell)
	13.2 Ah	(10hr, 1.32A, 1.75V/cell)
	12.5 Ah	(5hr, 2.41A, 1.75V/cell)
	10.7 Ah	(3hr, 3.57A, 1.75V/cell)
	9.20 Ah	(1hr, 9.20A, 1.60V/cell)
Max. Discharge Current	210A (5s)	
Internal Resistance (25°C)	Approx 14mΩ	
Operating Temp. Range	Discharge	-15 ~ 50°C (5 ~ 122°F)
	Charge	-20 ~ 45°C (-4 ~ 113°F)
	Storage	-15 ~ 40°C (5 ~ 104°F)
Nominal Operating Temp. Range	25±3°C (77±5°F)	
Cycle Use	Initial Charging Current less than 4.2A. Voltage 14.4V~15.0V at 25°C(77°F)Temp. Coefficient -30mV/°C	
	Standby Use	
Effect of temp. to Capacity	40°C (104°F)	103%
	25°C (77°F)	100%
	0°C (32°F)	86%
Self Discharge	US series batteries may be stored for up to 6 months at 25°C(77°F) and then a freshening charge is required. For higher temperatures the time interval will be shorter.	



## Layout

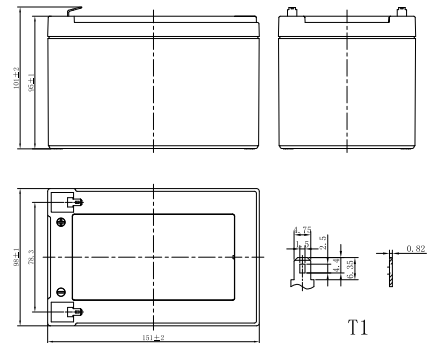

## Constant Current Discharge (Amperes) at 25 °C (77°F)

F.V/Time	5min	10min	15min	20min	30min	45min	1h	1.5h	2h	3h	4h	5h	6h	8h	10h	20h
1.85V/cell	44.2	30.3	23.6	19.2	13.9	10.2	8.33	6.10	4.79	3.46	2.76	2.35	2.01	1.58	1.29	0.684
1.80V/cell	47.5	32.1	24.7	19.9	14.3	10.4	8.53	6.23	4.88	3.52	2.80	2.38	2.04	1.60	1.31	0.700
1.75V/cell	50.0	33.4	25.5	20.5	14.7	10.7	8.70	6.34	4.97	3.57	2.83	2.41	2.06	1.62	1.32	0.703
1.70V/cell	52.4	34.7	26.4	21.1	15.1	10.9	8.86	6.45	5.04	3.62	2.87	2.44	2.09	1.64	1.34	0.706
1.67V/cell	54.2	35.7	27.0	21.5	15.3	11.1	9.00	6.53	5.10	3.66	2.90	2.46	2.11	1.65	1.35	0.711
1.60V/cell	57.5	37.2	28.0	22.2	15.8	11.4	9.20	6.67	5.20	3.73	2.95	2.50	2.14	1.68	1.36	0.719

## Constant Power Discharge (Watts/cell) at 25 °C (77°F)

F.V/Time	5min	10min	15min	20min	30min	45min	1h	1.5h	2h	3h	4h	5h	6h	8h	10h	20h
1.85V/cell	83.5	57.6	45.1	36.9	26.9	19.7	16.2	11.9	9.38	6.80	5.43	4.63	3.97	3.14	2.57	1.37
1.80V/cell	89.0	60.7	47.1	38.2	27.6	20.2	16.5	12.1	9.53	6.90	5.50	4.69	4.03	3.18	2.60	1.38
1.75V/cell	92.7	62.6	48.3	39.0	28.2	20.5	16.8	12.3	9.68	6.99	5.57	4.74	4.07	3.21	2.63	1.40
1.70V/cell	96.1	64.7	49.6	39.9	28.8	20.9	17.1	12.5	9.80	7.08	5.63	4.80	4.11	3.24	2.65	1.41
1.67V/cell	98.7	66.2	50.7	40.7	29.2	21.2	17.3	12.6	9.89	7.14	5.68	4.84	4.15	3.27	2.67	1.42
1.60V/cell	102.7	68.1	52.1	41.7	29.8	21.6	17.6	12.8	10.05	7.25	5.76	4.90	4.20	3.31	2.70	1.44



## US Series-General Purpose US12-14(12V14Ah)

### Applications

- All purpose
- Uninterruptable Power Supply (UPS)
- Electric Power System (EPS)
- Emergency backup power supply
- Alarm and security system
- Communication power supply
- DC power supply
- Auto control system

### General Features

- 5 years design life(25°C)
- Special exhaust structure and sealing technology, safe and reliable, flexible installation, convenient maintenance
- PbCaSn alloy for plate grids: less gassing, less self-discharging
- High quality AGM separator: extend cycle life and prevent micro short circuit
- High purity raw material: ensure low self discharge rate

### Standards

- Compliance with IEC 60896 standards, EU Battery Directive
- CE Certified
- Manufactured @ ISO45001, ISO 9001 and ISO 14001 certified production facilities

### Discharge Characteristics

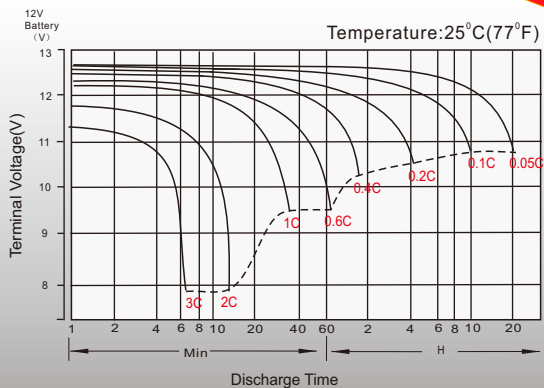

### Float Charging Characteristics

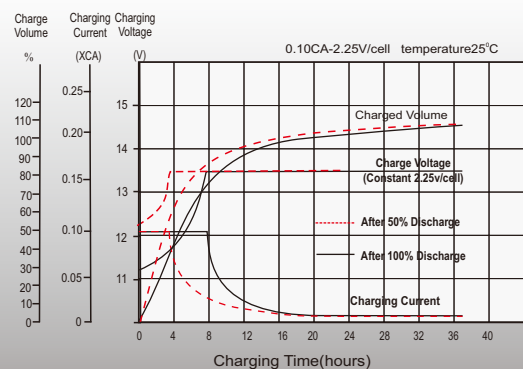

### Temperature Effects in Relation to Battery Capacity

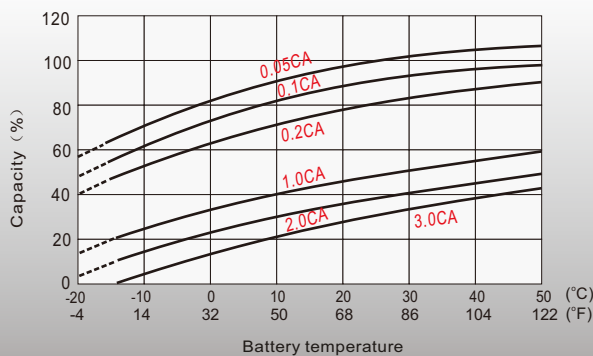

### Effect of Temperature on Long Term Float Life

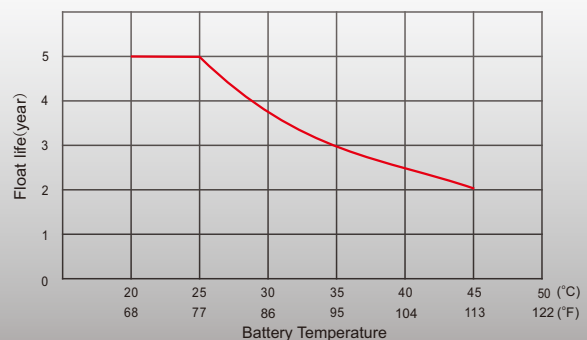

### Sales Offices Worldwide

#### China Sales Office

5th Floor, Xinbaohui Bldg., Nanhai Blvd.,  
Nanshan, Shenzhen, China. 518052  
Tel: +86-755-86036060 (100 lines)  
Fax: +86-755-26067269  
E-mail: export@leoch.com

#### HongKong Sales Office

Workshop C, 33/F, TML Tower, No. 3 Hoi Shing Road,  
Tsuen Wan, New Territories, Hong Kong  
Tel: +852 35786666  
Fax: +44 1452 690125  
E-mail: sales.hk@leoch.com

#### Singapore Sales Office

No. 1 Tech Park Crescent,  
Singapore 638131  
Tel: +65 68636078  
Fax: +65 6863 6079  
Email: sales.sg@leoch.com

#### Australia Sales Office

2 /29 Tarlington Place, Smithfield, NSW 2164  
Australia  
Tel: 02 9756 0950  
E-mail: sales.au@leoch.com

#### North America Sales Office

19751 Descartes  
Foothill Ranch, CA 92610, USA  
Tel: 949-588-5853  
Fax: 949-588-5966  
E-mail: sales@leoch.us  
Http://www.leoch.us

#### UK Sales Office

9B Wheatstone Court, Waterwells, Business Park,  
Gloucester, GL2-2AQ, UK United Kingdom  
Tel: +44(0) 1452 729428 / 1452 729696  
Fax: +44 1452 690125  
E-mail: Sales.Europe@leoch.com  
Http://www.leoch.eu

#### EMEA Sales Office

1 Deligiorgi St., 121 31 Athens,  
Greece  
Tel: +30 210 5760318 (2 lines)  
E-mail: support\_EMEA@leoch.com  
Http://www.leoch.eu

#### India Sales Office

Shed no.A-53(b), 2nd Stage of Peenya Industrial Area,  
Bangalore North Taluk, Bangalore-560058, India  
Tel: +91-80-23440018/23440019  
Fax: +91-80-23440017  
E-mail: indiasales@leoch.com